



Fork Light Bracket BMW K75/100

P/N 100101v4

Kit Contents	Tools Required
(2) stainless steel brackets (4) stainless steel spacers (4) stainless steel bolts - M6x80mm (4) stainless steel washers (4) stainless steel nuts – M6 (1) Permatex medium threadlocker - .5ml	5mm Allen Wrench 10mm Combination Wrench

READ ENTIRE INSTRUCTIONS PRIOR TO INSTALLATION

*****CAUTION: BIKE PARTS MAY BE HOT*****

Installation Instructions:

1. Support bike on stand (center stand preferred if equipped).
2. Before removing original bolts, make note of where the original washers are located (**E** Fig. 1). They will be reinstalled in the same position.
3. Unscrew the original bolt.
4. Remove the original bolt slowly. Be sure to retain the original washers (**E** Fig. 1). **Note:** Washer could fall out and be difficult to find if allowed to drop.
5. Orient the bracket (**C** Fig. 1) so the flange with two pill shaped holes is perpendicular to the fork tube and above the inscribed part number.
6. Apply threadlocker to at least 1/4" of threads at the bottom of one M6x80mm kit bolt (**A** Fig. 1). **Note:** threadlocker will dry within several minutes.
7. Install one M6x80mm kit bolt (**A** Fig. 1) from this kit in the following order, installing the kit nut (**F** Fig. 1) loosely (see Fig. 1 for reference):
Kit Bolt -> Kit Washer -> Kit Bracket -> Kit Spacer -> ORIGINAL Pieces -> Kit Nut
8. Repeat steps 2 through 7 for the second bolt (letting the bracket loosely hang for easy removal of the second original bolt).
9. Tighten both nuts (**F** Fig. 1), alternating back and forth between the nuts tightening each a little at a time.
10. Repeat all steps for second bracket on opposite side of the fork.
11. Please follow manufacturer instructions for installing fog or driving lights.

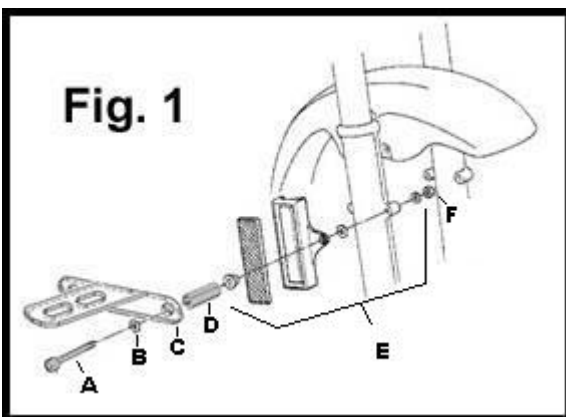

Disclaimer:

Lamp One Designs shall not be responsible for any loss, liability, damage (whether direct, indirect or consequential), personal injury or expense of any nature whatsoever which may be suffered by you or any third party as a result of or which may be attributable, directly or indirectly, to your use of these parts.